

REDIRACKS™

Burco® S-Series/Universal Windshield Carriers Assembly & Instruction Manual

S-Series models and specifications:

S-05B (15" Mast Height): 5-Lite Capacity. Dimensions: 18"(L) x 30"(W) x 18"(H)

S-0918B (18" Mast Height): 9-Lite Capacity. Dimensions: 30" (L) x 30" (W) x 21" (H)

S-0924B (24" Mast Height): 9-Lite Capacity. Dimensions: 30"(L) x 30"(W) x 27"(H)

S-111524B (15" & 24" Mast Height): 11-Lite Capacity. Dimensions: 36"(L) x 30"(W) x 27"(H)

S-1418B (18" Mast Height): 14-Lite Capacity. Dimensions: 45" (L) x 30" (W) x 21" (H)

S-1424B (24" Mast Height): 14-Lite Capacity. Dimensions: 45"(L) x 30"(W) x 27"(H)

S-17x42B (15" Mast Height): 17-Lite Capacity. Dimensions: 42"(L) x 30"(W) x 18"(H)

S-19x48B (15" Mast Height): 19-Lite Capacity. Dimensions: 48"(L) x 30"(W) x 18"(H)



Technical Assembly Required

Save these instructions for future use

Visit us online at www.burcoinc.com. Burco, Inc.® 2936 S. Wilson Court NW | Grand Rapids, MI 49534. If you have any questions regarding your BURCO® REDI RACK™ assembly, please call 800.253-2593

Contents

Tools Required	3
Inside This Package	4
Ordering Replacement Parts	5
Assembly Instructions	6
Step 1: Place End Brackets.....	6
Step 2: Place 4 Fasteners.....	6
Step 3: Place last Side Rail.....	7
Step 4: Place 4 Fasteners.....	7
Step 5: Tighten all Fasteners.....	8
Mounting Advisements	9

Tools Required for Installation

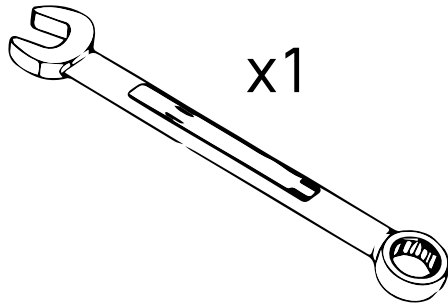

(9/16" Box End Wrench)

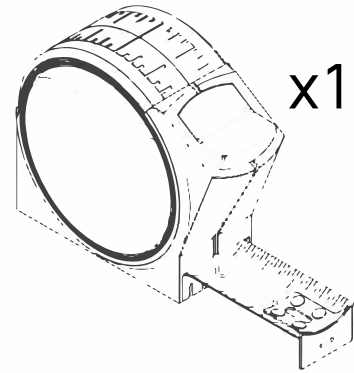

(Tape Measure)

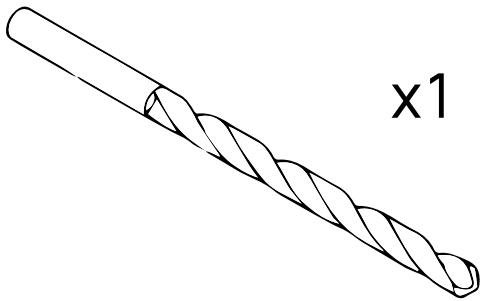

(Letter "X" Drill Bit)



(Cordless Drill)

Inside This Package

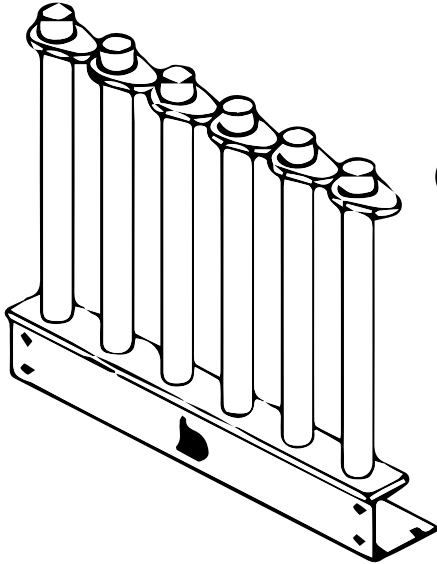

x2
(Side Rail)

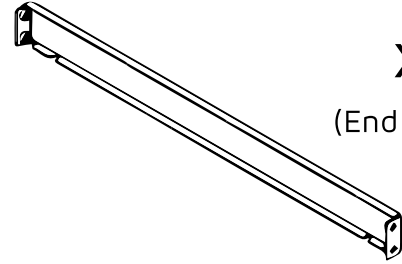

x2
(End Bracket)

(REP-04)



x1
(Slick Eddy™)

(SE-46)

To prolong the life of the rubber strip, the Slick Eddy should be used each time a windshield is reoved or placed into the Redi Rack™.

Hardware Kit

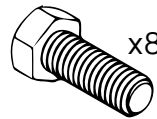

x8
(3/8-16 UNC x 3/4" Bolt)



x16*
(3/8" Flat Washer)



x12*
(3/8" Lock Washer)



x4*
(3/8-16 UNC Hex Nut)

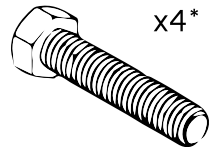

x4*
(3/8-16 UNC x 1.75" Bolt)

* Extra hardware included for use with S-111524B, S-17x42B, S-19x48B installations. See page 9 illustration for placement of extra hardware. (2 nuts, 2 bolts, 2 lock washers, 4 flat washers)

Replacement Parts for Burco® S-Series Redi Racks™

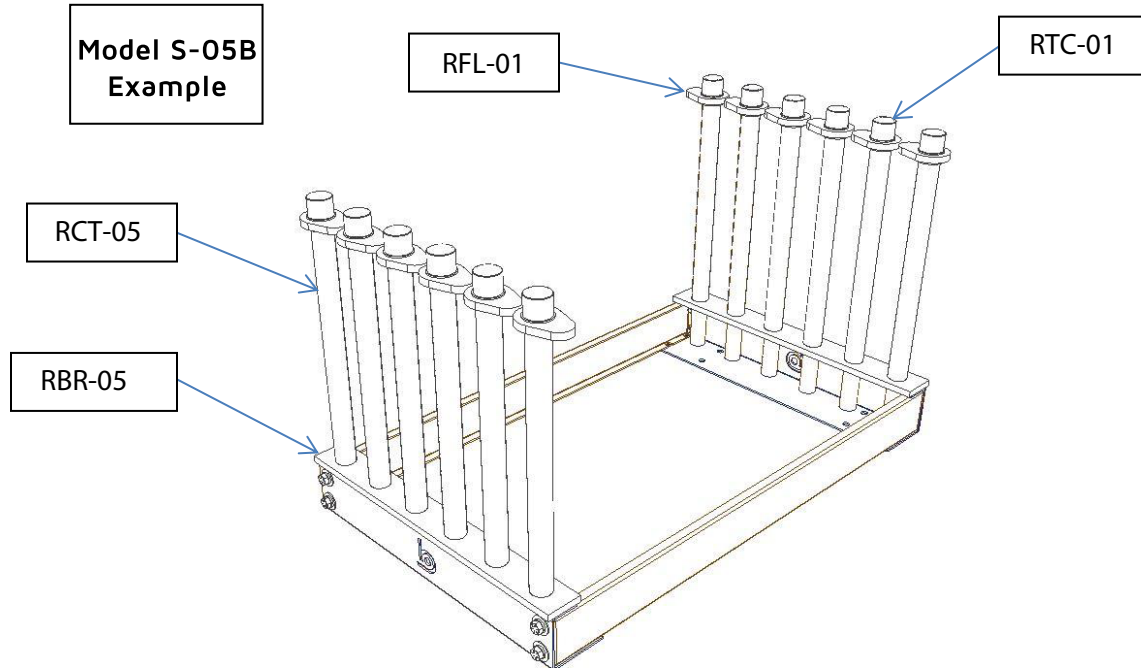

Burco's patented fingerlock design is exclusive and proprietary to Burco® For use with Burco® Redi Racks ONLY

REPLACEMENT PARTS FOR BURCO S-SERIES REDI RACKS™

Item:	Description:	Fits Models:
RTC-01	Rubber Top Cap	All S-Series
RFL-01	Rubber Finger Lock™	All S-Series
RFL-03	Rubber Finger Lock™ Oversized	S-111524B (two inner 15" masts)
RCT-01	13.75" Rubber Mast Tubing	Models with 15" masts
RCT-04	22.75" Rubber Mast Tubing	Models with 24" masts
RCT-20	17" Rubber Mast Tubing	Models with 18" masts
RBR-05	5-Lite Bottom Rubber Strip 3" on ctr.	S-0518B
RBR-09	9-Lite Bottom Rubber Strip 3" on ctr.	S-0918B, S-0924B
RBR-11	11-Lite Bottom Rubber Strip 3" on ctr.	S-111524B
RBR-14	14-Lite Bottom Rubber Strip 3" on ctr.	S-14B, S-1424B
RBR-17x42B	17-Lite Bottom Rubber Strip 2.3" on ctr.	S-17x42B
RBR-19x48B	19-Lite Bottom Rubber Strip 2.3" on ctr.	S-19x48B
SE-46	Slick Eddy™ Glass Slide tool	All S-Series

Assembly Instructions

Step 1: Place one of the side rail assemblies vertical and set end pieces inside the side rail channel as shown below.

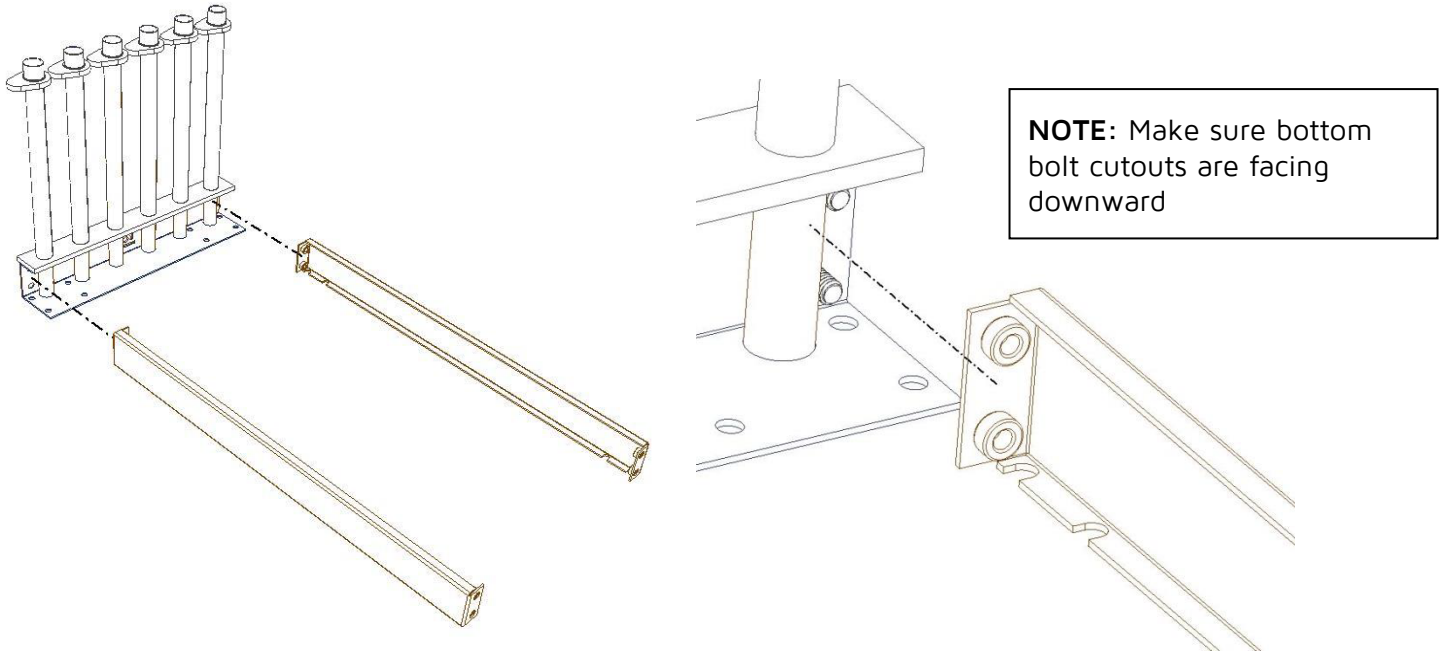

Step 2: Place a 3/8-16 x 3/4 UNC Hex head fastener with a lock washer and a flat washer into each of the four designated holes as shown below. **Tighten finger tight.**

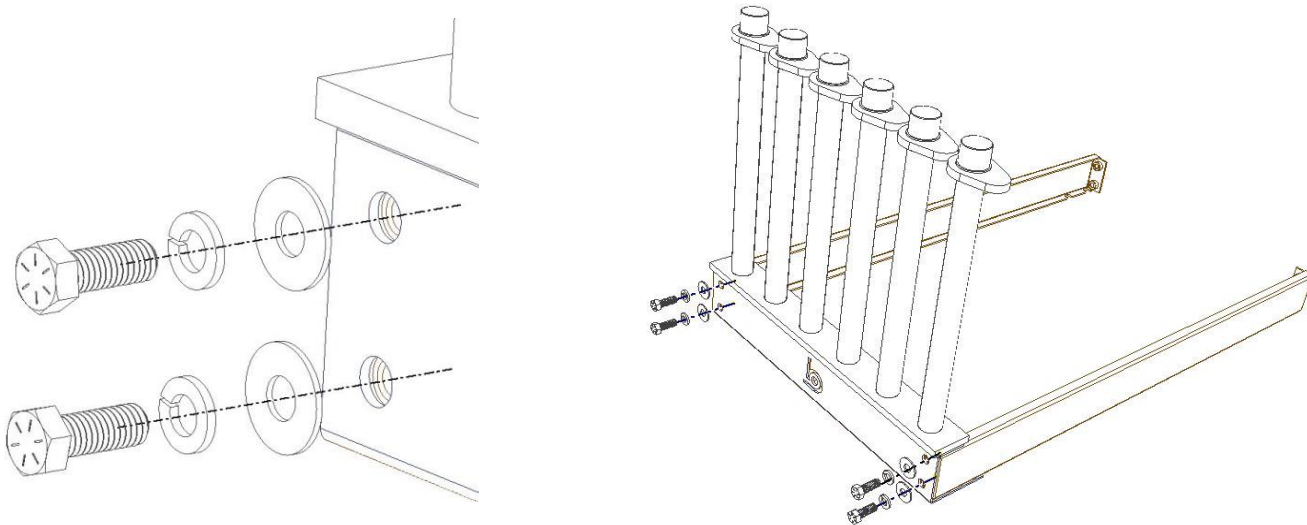

Assembly Instructions (Continued)

Step 3: Place the other side rail assembly vertically with both end brackets nested inside the side rail channel as shown below.

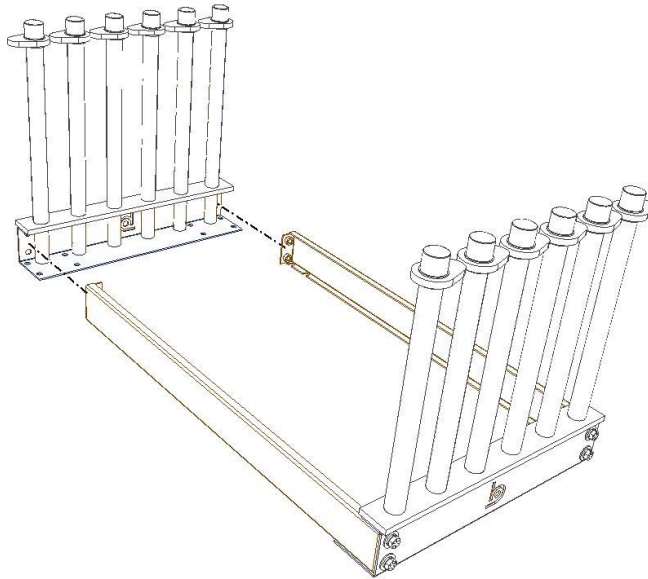

Step 4: Place a 3/8-16 x 3/4 UNC Hex head fastener with a lock washer and a flat washer into each of the four designated holes as shown below. **Only tighten fasteners finger tight for now.**

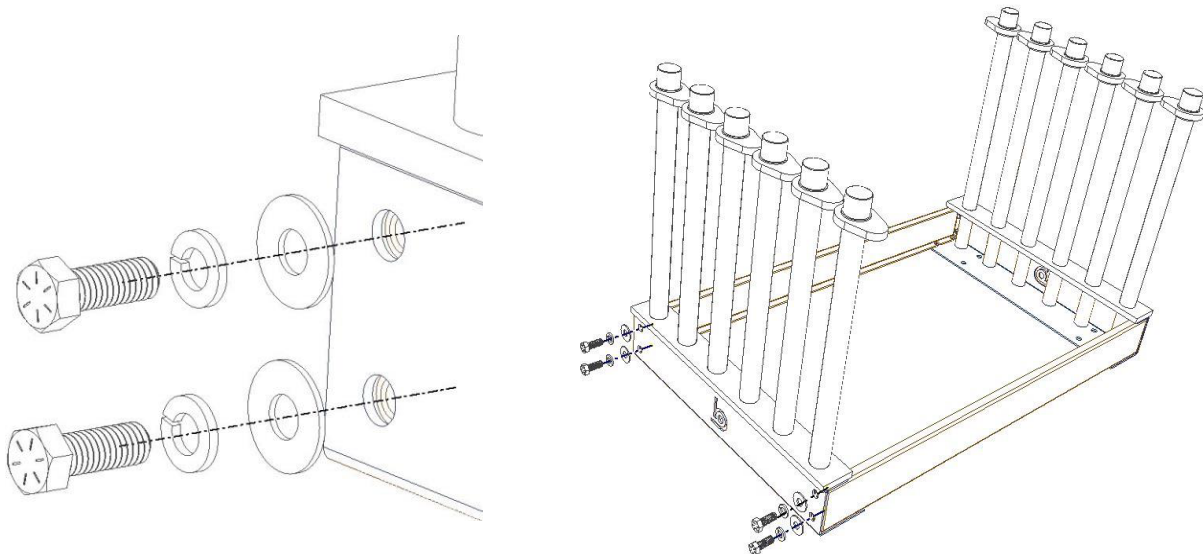

Assembly Instructions (Continued)

Step 5: Once all of the fasteners are in place and finger tight, use a 9/16" box end wrench to tighten the fasteners to approximately 30 lb.-ft. Once all eight of the bolts are tightened down, the Redi Rack is ready to be installed onto the mounting surface.

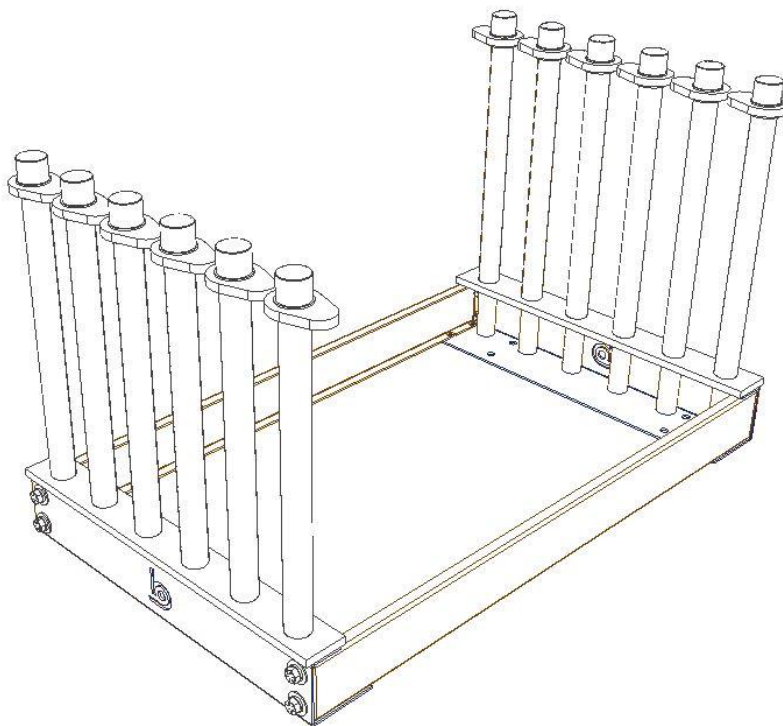

DISCLAIMER: IN NO EVENT, REGARDLESS OF CAUSE, SHALL BURCO INC.® BE LIABLE FOR ANY INDIRECT, SPECIAL, INCIDENTAL, PUNITIVE OR CONSEQUENTIAL DAMAGES OF ANY KIND, WHETHER ARISING UNDER BREACH OF CONTRACT, TORT (INCLUDING NEGLIGENCE), STRICT LIABILITY OR OTHERWISE, EVEN IF ADVISED OF THE POSSIBILITY OF SUCH DAMAGES.

Mounting Advisements

Measure and mark the center of the mounting surface so that you can easily center the rack. It is important that you center the rack onto the mounting surface to ensure even weight distribution. Once the rack is set in desired location, mark the four, *or six (for 11,17,19-lite models)* mounting locations where you will drill 3/8" clearance holes. **Prior to drilling, read all notes.** Drill all four *or six* holes with a letter "x" (.397") drill bit. Next, place the rack over the four *or six* drilled holes and place the supplied bolts and washers through the holes as shown in the diagram below. Lastly, from underneath the vehicle, securely tighten provided nuts, with washers, onto each of the four *or six* bolts that you placed through the mounting holes using the 9/16" box end wrench.

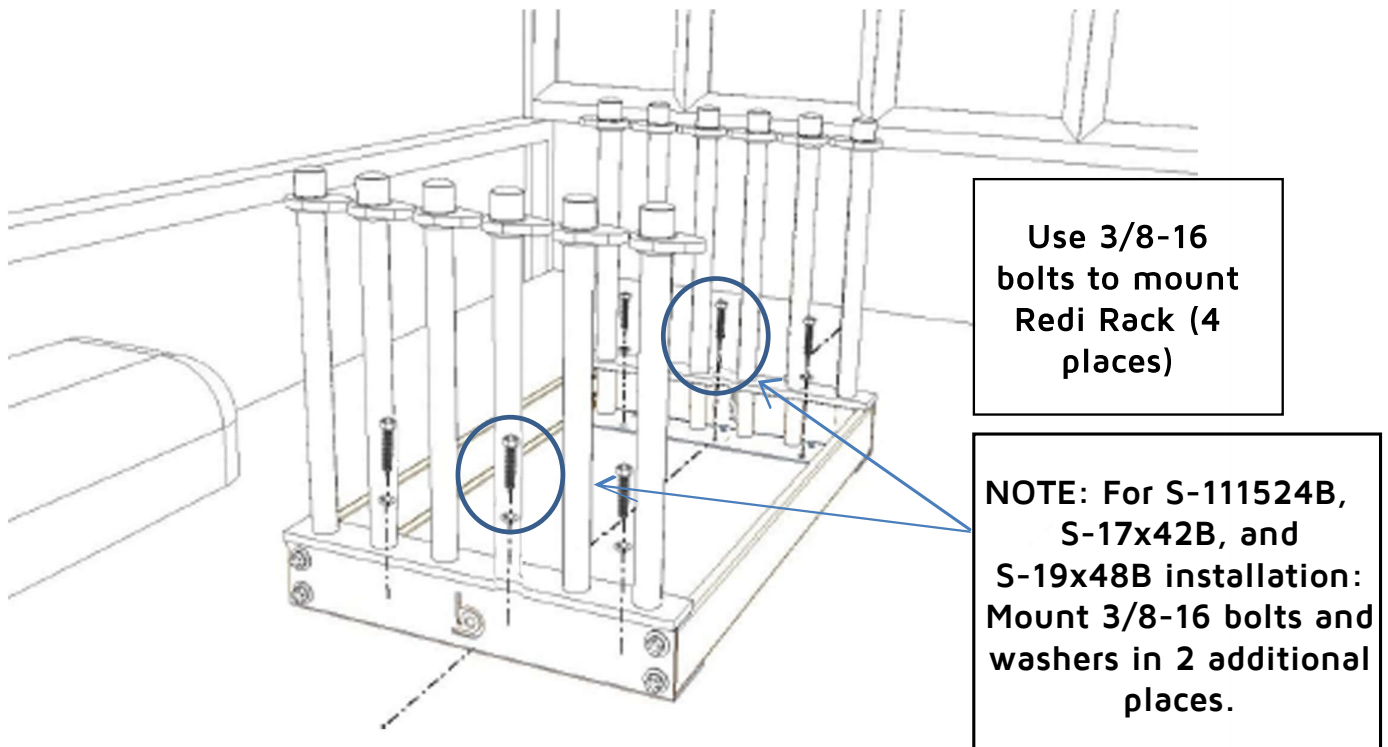

NOTE: PROFESSIONAL OR TECHNICAL INSTALLATION EXPERIENCE IS RECOMENDED FOR THE INSTALLATION OF ALL BURCO® REDI RACK™ SYSTEMS. BE AWARE OF ANY AND ALL EQUIPMENT THAT IS LOCATED BELOW RACK BEFORE INSTALLING. IF DRILLING HOLES INTO THE FLOOR OR BED OF A VEHICLE, VERIFY CLEARANCE OF ANY GAS LINES, GAS TANKS, EXHAUST PARTS OR ANYTHING ELSE THAT IS LOCATED UNDERNEATH THE MOUNTING HOLES.